



C-Con™ Converter Box Installation Instructions

The C-Con™ converts the signal from a C-Level™ sensor to simulate float levels (up to four floats). Activation levels can be conveniently set and adjusted at the C-Con™ converter box by using the output dials, eliminating the need to go into the tank to move float tether points. The converter box works well in wastewater pump tanks, confined space applications, and systems with high grease content.

Note: The C-Con™ converter box can be used with most panels using control switches. The C-Con™ converter box is not recommended for use with plugger type panels or intrinsically safe type panels. For assistance, please contact SJE Rhombus® customer service.

C-CON™



- Voltage: 120 VAC, 60 Hz, 44 mA
- Output contact rating: 3 amps 240 VAC (control load only).
- NEMA 1 rated for indoor use. (Can be mounted in a control panel.)
- Green power on indicator.
- Four independently adjustable output set points at the converter box with red LED status indicators.
- Adjustable pump start/stop and alarm levels from converter box.
- Simulate button for testing proper wiring of outputs.
- Factory-installed output and power wires.
- Works with most simplex or duplex control panels.
- Alternative to mercury float switches.
- Five-year limited warranty.

OPTIONS

This system is available with:

- C-Level™ sensor with 4' tube and 20' cable
- C-Level™ sensor with 4' tube and 40' cable
- C-Level™ sensor with 8' tube and 20' cable
- C-Level™ sensor with 8' tube and 40' cable
- Without C-Level™ sensor

PREVENTATIVE MAINTENANCE

- Periodically inspect the product. Check that the cable and vent tube have not been damaged so as to impair the performance of the product. Replace the product immediately if any damage is found or suspected.
- Use only SJE Rhombus® replacement parts.

SJE RHOMBUS® FIVE-YEAR LIMITED WARRANTY

For complete terms and conditions, please visit www.sjerrhombus.com.

NOTICE!

Products returned must be cleaned, sanitized, or decontaminated as necessary prior to shipment to ensure that employees will not be exposed to health hazards in handling said material. All applicable laws and regulations shall apply.

⚠ WARNING**ELECTRICAL SHOCK HAZARD**

Disconnect power before installing or servicing this product. A qualified service person must install and service this product according to applicable electrical and plumbing codes.

⚠ WARNING**EXPLOSION OR FIRE HAZARD**

Do not use this product with flammable liquids. Do not install in hazardous locations as defined by National Electrical Code, ANSI/NFPA 70.

Failure to follow these precautions could result in serious injury or death. Replace product immediately if switch cable becomes damaged or severed. Keep these instructions with warranty after installation. This product must be installed in accordance with National Electric Code, ANSI/NFPA 70 so as to prevent moisture from entering or accumulating within boxes, conduit bodies, fittings, float housing, or cable.

INSTALLING THE C-CON™ CONVERTER BOX

Caution: Operating temperature for C-Con™ converter box is -40°F (-40°C) to 140°F (60°C).

1. Determine a mounting location for the controller inside the panel. The controller can be mounted using the integral mounting flange and provided screws or another available method.
2. The C-Con™ converter box requires 120 VAC power supply. Simply connect the white neutral wire (N) to the neutral in the panel. Connect the blue power wire (L1) to 120 VAC power in the panel. Connect the output wires to the float input connection points in the panel. Refer to panel schematic for terminal block positions and torque requirements. (See Figure A)
3. Using the wire nuts provided, connect the red, white, and black wires from the C-Level™ sensor to the red, white and black wires from the C-Con™ converter box. See Figure A.
Caution: Improper wiring of the C-Level™ sensor can cause the sensor to fail. Shielding on C-Level™ sensor cable must be connected to ground.
4. A high water alarm float can be installed as a redundant method of sounding the alarm. Install the alarm float wires in the appropriate terminal block locations along with the C-Con™ converter box output wires.

INSTALLING THE C-LEVEL™ SENSOR

Caution: The C-Level™ sensor cable needs to run in separate conduit from the pump and power lines. Operating temperature for the C-Level™ sensor is 32°F (0°C) to 120°F (50°C).

1. Determine the normal operating levels for the configuration as shown in **Figures B & C**.
2. Position the C-Level™ sensor at the appropriate location on the pipe and secure the sensor and vent as shown in **Figure D**.
Warning: Do not support the C-Level™ sensor by the cable. Position the sensor in the tank so that nothing is pushing on the diaphragm.
3. Position the vent so that it is above the water level and stow the excess vent tube.
Warning: Do NOT kink or place black tubing under the hose clamp. Doing so will cause the sensor to fail.
4. Tighten all hose clamps using a screw driver. Over-tightening may result in damage to the plastic parts.
Note: All hose clamp components are made of 18-8 stainless steel material. See your SJE Rhombus® supplier for replacement parts.

SETTING THE OUTPUTS ON THE C-CON™ CONVERTER BOX

To adjust the activation levels for the four outputs, turn the dials on the C-Con™ converter box to the desired depth in inches. When the liquid reaches that depth, the corresponding output will close simulating a float switch closure.

IMPORTANT: The liquid level in inches is measured from the zero point as shown in **Figures B, C & D**. Example: If the dial is set to 3 inches, the corresponding liquid level is 3 inches above the zero point.

IMPORTANT: The dial settings on the C-Con™ converter box are approximate level settings. It is important to cycle the system after setting the levels to verify the outputs close at the desired liquid levels in the tank. The minimum recommended setting for output #1 is 2 inches.

The simulate button on the C-Con™ converter box can be used to verify proper wiring of the output wires. To use this feature, the outputs need to be in the OFF mode. With the outputs off, simply push and hold the simulate button. The outputs will automatically close sequentially (1-4) and then open (4-1). This allows the installer to verify system operation. It is important to know that the simulate button does not verify proper wiring of the C-Level™ sensor or proper setting of the output dials.

TEST THE SYSTEM

To verify correct wiring and setting of the activation levels, perform the following steps:

1. Start with the liquid level in the tank pumped down so all four outputs on the C-Con™ converter box are off.
2. Turn the pump breaker(s) off and start filling the tank.
3. Watch as the liquid level rises and verify that each status indicator on the C-Con™ converter box turns on at the appropriate actual liquid level.
4. Once the activation set points have been verified, turn the pump breaker(s) on. The pump will start.
5. Verify that the pump stops at the appropriate liquid level.

Figure A

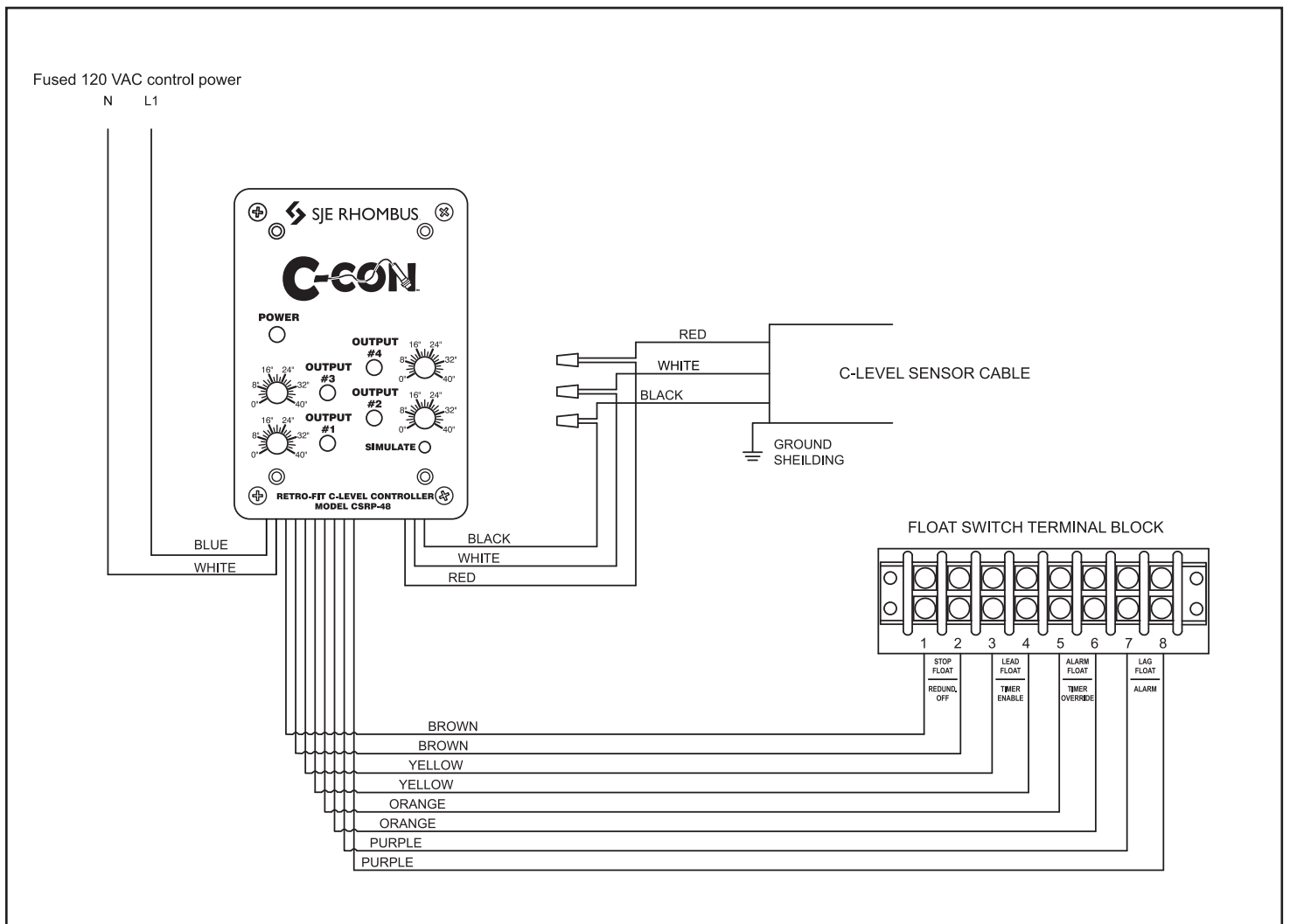

Figure B - Timed Dose

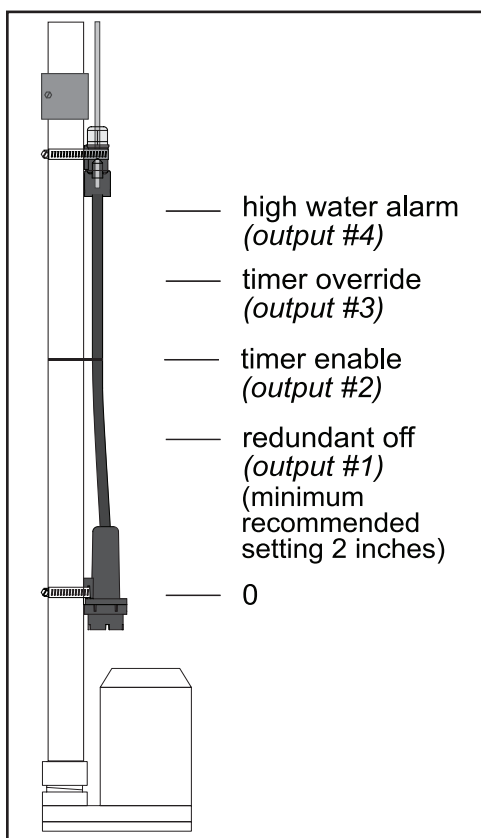

Figure C - Demand Dose

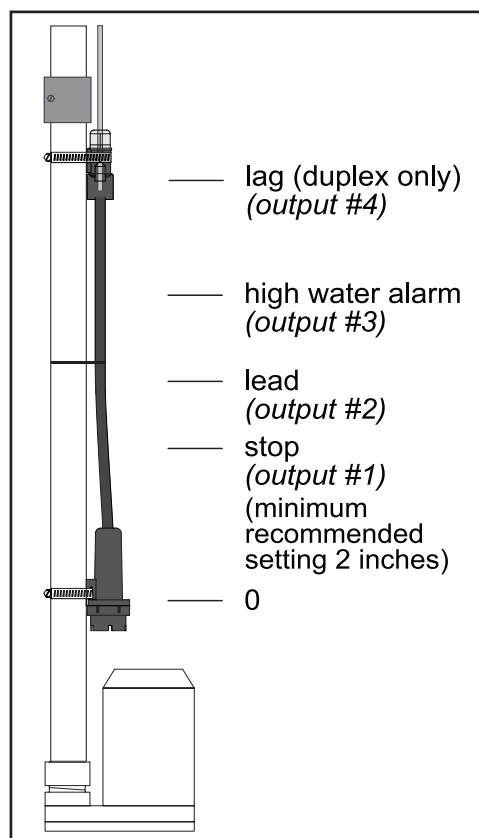

Figure D

